

Issue 1

ASSEMBLY INSTRUCTIONS

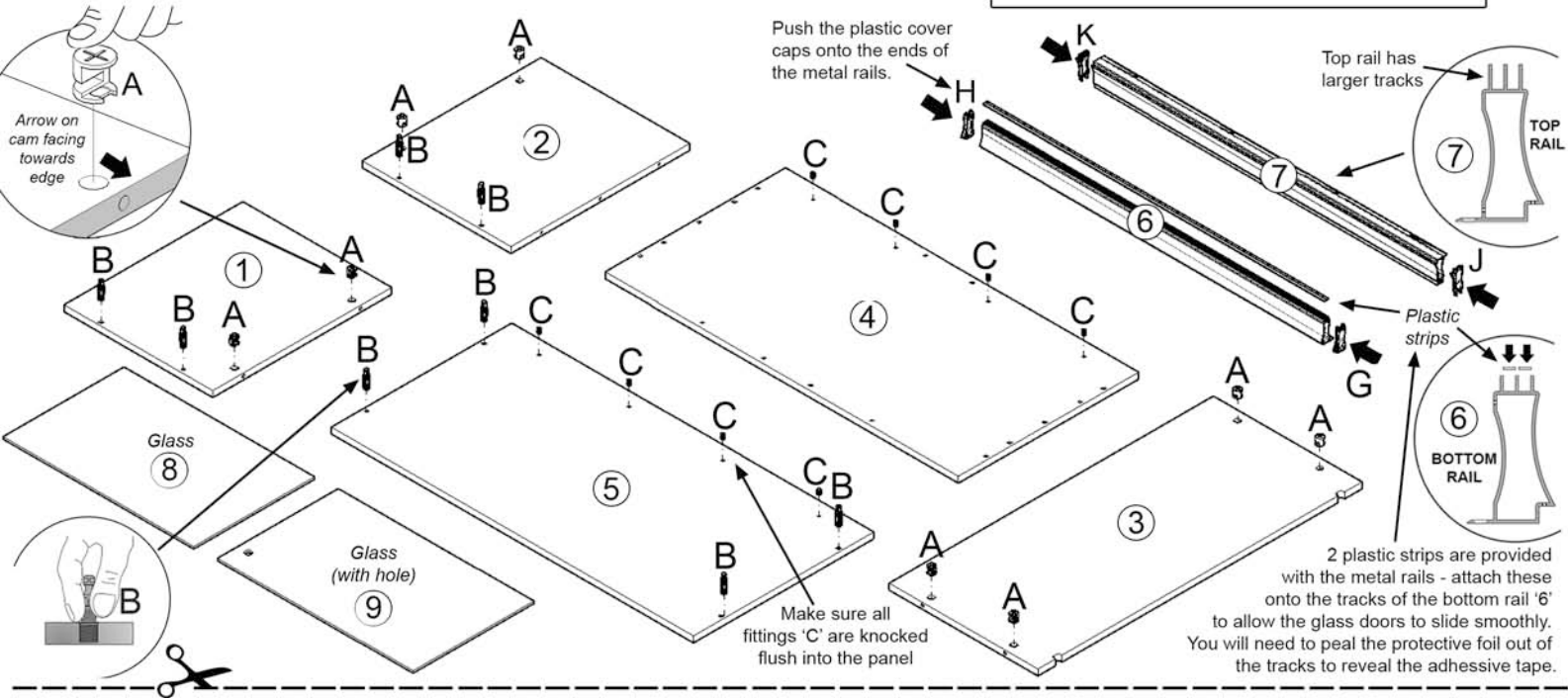
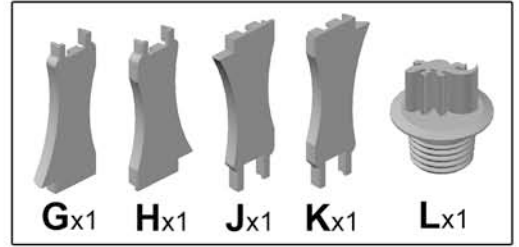
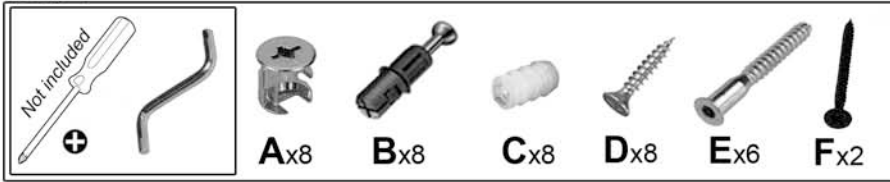

A matching Viva cabinet can be purchased separately to fit directly onto the base of the vivarium.

Please visit
www.vivexotic.co.uk
for more information

We recommend Exo Terra reptile accessories for use with Vivexotic products. Please refer to the 'Exo Terra Essential Care & Equipment Guide' included for further details.



SILICON SEALING

We recommend that you seal this product with silicon once constructed to prevent leakage and to help ensure the product has a long life.

Simply run silicon along all joins and areas of exposed chipboard (such as cam holes) and leave overnight to cure.



PARTS CHECKLIST

Before commencing assembly, please check that all components are present and correct. If any parts are missing or damaged please complete this form and send back to us by fax 01977 513465 or by email customer.service-uk@rchagen.com. This form can be downloaded from our website www.vivexotic.co.uk.

1. PRODUCT INFORMATION

Please provide the following product details. This information can be found on the barcode label attached to the outside of the box.

Product Code	
Batch Number	

2. PERSONAL DETAILS

Name	
Company (if applicable)	
Telephone	
Email	
Delivery Address	
Postcode	

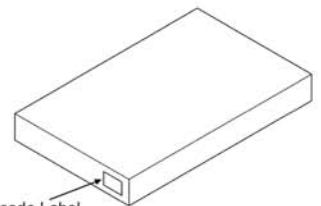

3. PURCHASE & DELIVERY INFORMATION

Date Purchased	
Where was the item purchased	

Please send a proof of purchase along with this form (keep the original safe and send a copy).

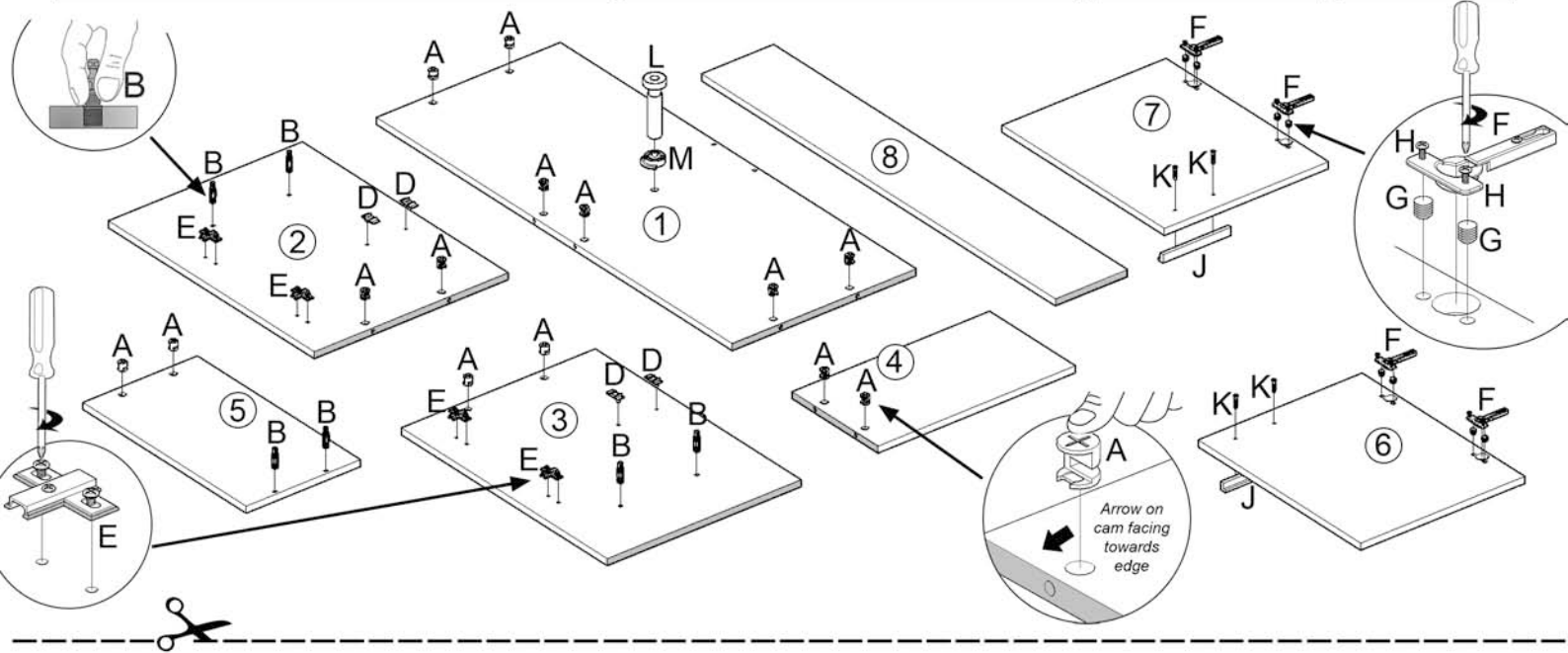
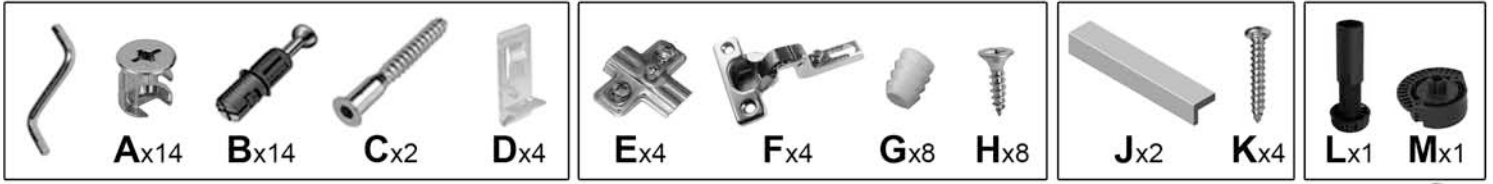

This cabinet was designed to attach onto the bottom of the following items.

Please visit
www.vivexotic.co.uk
 for more information



PARTS CHECKLIST

Before commencing assembly, please check that all components are present and correct. If any parts are missing or damaged please complete this form and send back to us by fax 01977 513465 or by email customer.service-uk@rchagen.com. This form can be downloaded from our website www.vivexotic.co.uk.

1. PRODUCT INFORMATION

Please provide the following product details. This information can be found on the barcode label attached to the outside of the box.

Product Code	
Batch Number	

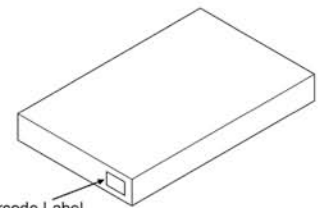

2. PERSONAL DETAILS

Name	
Company (if applicable)	
Telephone	
Email	
Delivery Address	
Postcode	

3. PURCHASE & DELIVERY INFORMATION

Date Purchased	
Where was the item purchased	

Please send a proof of purchase along with this form (keep the original safe and send a copy).

ASSEMBLY x2

Turn the vivarium that you are using with this cabinet upside down (with the glass out) and insert 8 x 'B'

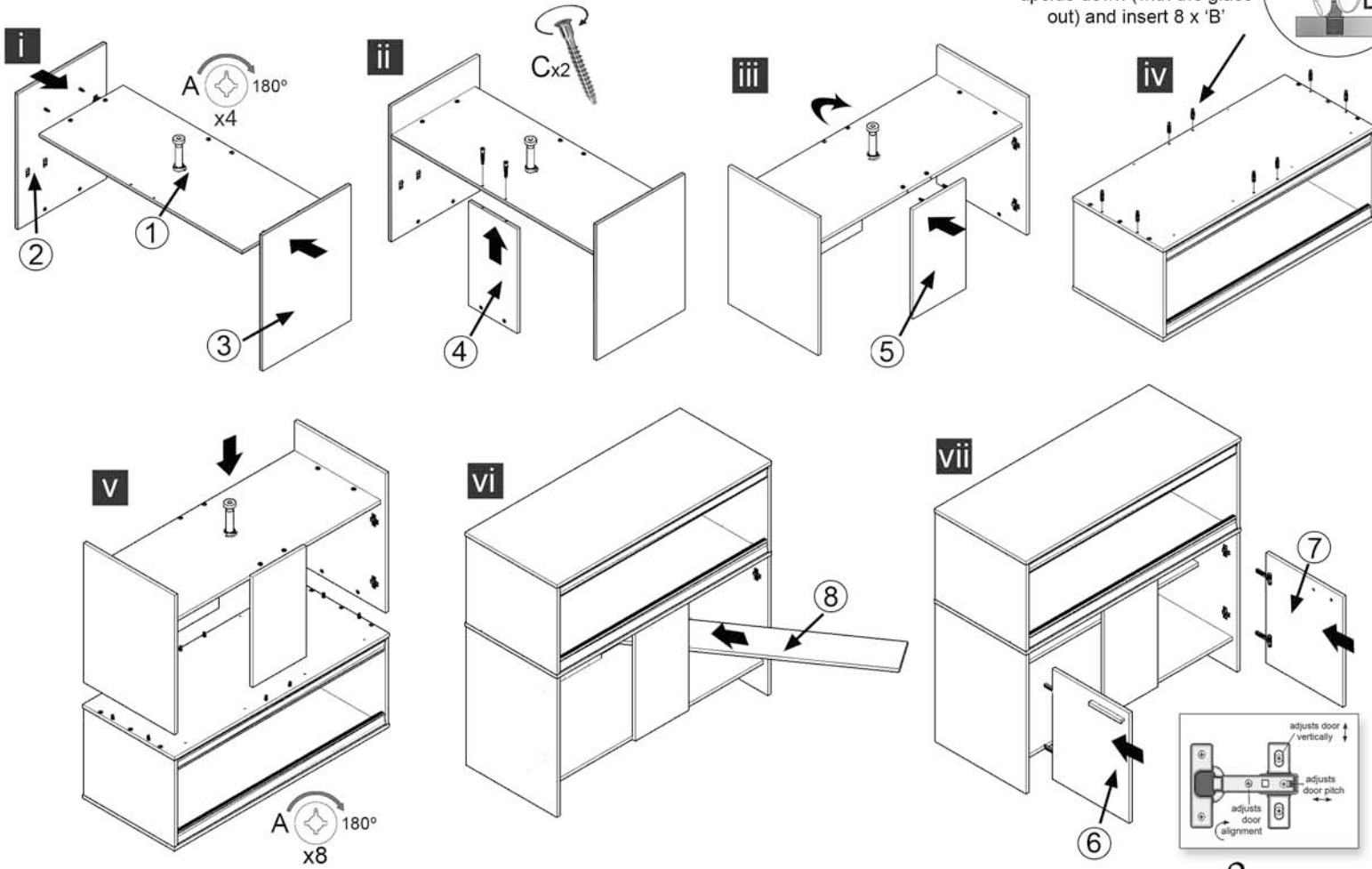

2 YEAR EXTENDED WARRANTY

You have automatically received a standard 12 month guarantee with your purchase, however if you fill out the warranty card below, you will receive an extra 12 months free, giving you a total of 2 years warranty from the date of purchase.

Name		Date of Purchase		Please send back to: Rolf C Hagen (UK) Ltd California Drive, Whitwood Ind Estate, Castleford, West Yorkshire, WF10 5QH
Email		Place of Purchase		
Address		Stock Number <small>(see edge of box)</small>		
Age	<input type="checkbox"/> 16-25 <input type="checkbox"/> 26-35 <input type="checkbox"/> 36-50 <input type="checkbox"/> 51-65 <input type="checkbox"/> 66+	Reptiles Kept		
Product Purchased				The standard and extended warranty covers for defective parts which have failed under normal use. We shall not replace parts that have been damaged by abnormal conditions or that which have been subjected to improper use. It is important that you seal your vivarium to prevent moisture entering into exposed chipboard. We will not replace parts that have been water damaged due to insufficient sealing. If not sealed correctly, this will invalidate the warranty.
Colour				

Please send a proof of purchase along with this form (keep the original, send a copy).

How was your item delivered?

- Collected by yourself
 Delivered by a courier
 Other (please specify) _____

4. DETAILS OF PROBLEM

What is the problem? (* Please supply a photo to highlight the issue)

- | | | | |
|---|--|--|--|
| <input type="checkbox"/> Damaged Panel *
Damaged on delivery? Y / N | <input type="checkbox"/> Broken glass *
Broken on delivery? Y / N | <input type="checkbox"/> Wrongly drilled panel * | <input type="checkbox"/> Missing plastic runners |
| <input type="checkbox"/> Missing fittings
Whole pack or individual fittings? | <input type="checkbox"/> Damaged plastic runners *
Damaged on delivery? Y / N | <input type="checkbox"/> Glass doesn't fit * | <input type="checkbox"/> Wrongly sized part * |
| <input type="checkbox"/> Other missing part | <input type="checkbox"/> Other (please specify) * _____ | | |

Please detail the parts required, and the quantity below:

Item	Part	Quantity	Problem
Panel (example)	Back	1	Broken at top left hand corner
Fitting (example)	C	2	Missing from pack

Please send the following items with this form:

- PROOF OF PURCHASE** (please keep the original receipt safe and send a copy)
- PHOTOS DETAILING THE PROBLEM** (unless parts are missing)